

Cabinet Parts and Options (cont'd)

Code	Description	Size										
		25	50	75	100	125	130	165	200	250	300	400
145	Vertical Louver Assembly (same as CD1)	98500	98501	98502	136863	98503	98504	98505	98506	98507		
145A	Vertical Louver Top/Btm Member only	97852	97853	97854	97856	97854	97855	97856	97857	97858		
145B	Vertical Louver only		95937					95938				
146	Duct Flange Kit (Same as CD9)—B/BE	101194	101194	101195	101501	135591	101196	101197	101198	101199	101199	101200
146A	Duct Flange Top & Btm—in CD9 & AX4	101155	101155	101156	101157	101159	101157	101158	101159	101160	101160	101161
146B	Duct Flange Sides—in CD9 & AX4	101163	101163	101163	101163	101163	101164	101164	101164	101164	101164	101164
147	Maroon Touch-up Paint, 12oz spray can	207432 (louver color)										

Code 145 - Vertical Louver Assembly (same as Option CD1)

On fan models, do not use vertical louvers with optional discharge nozzles.

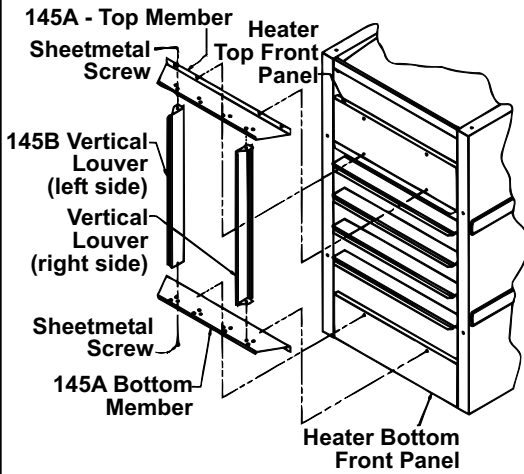

Code 146 - Duct Flange Parts (same as Option CD9; components used in Option AX4)



Code 149 - Vent Cap—Model F/B with Gravity Vent

NOTE: Same type of vent cap applies to a gravity or power vent installation. The required size of vent cap varies; for power vent sizes, see Code 80, page 14, for FE and BE or Code 101, page 15, for F and B with power vent option.



Applies to Model F&B Size with a gravity vent	Vent Cap Diameter (Inches)	PN
25-50	4	111848
75	5	111849
100	6	111850
125, 130	8*	61857
165, 200	8	61857
250, 300	10	61866
400	12	61875

*Run 7" vent pipe and use a field-supplied increaser with an 8" vent cap.

Hangers and Optional Hanger Kits

Code	Description	Models	PN
150	Hanger Bracket Assembly (2 standard on each fan unit, 4 standard on each blower unit)	F/FE25-400 & B/BE25-400	96386
151	Four-Point Suspension Kit (Same as Option CK7)	F/FE25-400	98508
152	Swivel Connection Kit for Two-Point Suspension (Same as Option CK8)	F/FE25-400	98509
153	Four-Point Suspension with Swivel Connections Kit (Same as Option CK9)	F/FE25-400	98510
154	Swivel Connection Kit for Four-Point Suspension (Same as Option CK10)	F/FE25-400 & B/BE25-400	98511
Components in Swivel Connection Hanger Kits CK8, CK9, and CK10 listed above:			
	Swivel Connection only (to adapt for hanging from 1" threaded pipe)	All	17627
	Lock Washers for installing Swivel Connections	All	5197
155	Pressure Switch Bracket only, required when installing Code 151 or 153 on Model FE Sizes 25-100 mfgd before AUG 1992 (Date Code ARI)	FE 25-100 mfgd before AUG 1992, order separately (not included in option kits)	98448
156	8-32 Nut for installation of Pressure Switch Bracket (Code 155)		31522
157	Four-Point Suspension Kit designed to carry a nearly equal load at each suspension point (Same as Option CK19)	B/BE165-400	165742
Components in Hanger Kit Option CK19:			
157A	Right Side Hanger Bar	B/BE165-400	162829
157B	Left Side Hanger Bar	B/BE165-400	162830
157C	HHD Tap Bolts 3/8-16NC x 11-1/2 #5	B/BE165-400	(4)114350
157D	3/8" Lockwasher	B/BE165-400	(8)5197

Code 150 - Hanger Bracket



Code 151 - Kit to Convert Fan Model to 4-Pt Suspension (same as Option CK7)



Code 152 - Swivel Connection Kit for 2-Pt Suspension



(same as Opt CK8)

Code 153 - Kit to Convert to 4-Pt Suspension with Swivel Connections (same as Option CK9)



Code 154 - Swivel Connection Kit for 4-Pt Suspension (same as Option CK10)



Code 157 - 4-Pt Suspension for Models B/BE, designed to equalize the load (same as Option CK19)

